

## Very high pressure sensor

3.80 mm up to 185C°

MHP-3.80-002-XXX-S-YYYY-A-ZZ

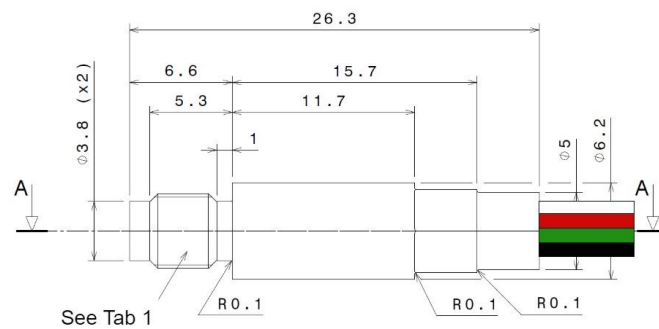
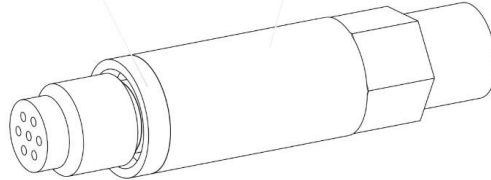

Tab 1	
Type	Value
Metric	M5x0.5
Imperial	10-32 UNF-2A

### MODEL DEFINITION

**XXX:** SST: mechanical casing in stainless steel  
**S:** M for metric, I for Imperial  
**YYYY:** pressure range in PSI (1000, 3000)  
**A:** absolute pressure measurement  
**ZZ:** ST: standard temperature up to 100C°  
 HT: high temperature up to 185C°  
**Options:** special tube length, material and grid shape also available on request

### WIRE COLOR CODE

BLACK	Input -
RED	Input +
WHITE	Output -
GREEN	Output +

### OVERVIEW

- Outer diameter 3.80 mm
- From 1000 to 3000 psi Absolute pressure sensor
- Wide temperature range up to 185C°
- Harsh environment
- Customized solution possible
- mVolt output
- Highest resonance frequency on the market
- Amplification can be done for a special request

### APPLICATIONS

- Instrumentation (ie: Automotive, ...)
- Aerodynamic testing (ie: wind tunnel)
- Industrial process monitoring
- Pumps
- Biomedical
- Oil and gas
- ...

PART NUMBER

MHP-3.80-002-XXX-S-YYYY-A-ZZ

Pressure Range	Burst Pressure
0 → 1000 PSI	3000 PSI
0 → 3000 PSI	9000 PSI

Characteristic	Minimum	Typical	Maximum	Unit
Span <sup>4@</sup> 5V	0 → 1000 PSI	125	145	mV
	0 → 3000 PSI	180	210	
Zero Offset <sup>1</sup>	-10	0	10	mV/V
Bridge Resistance (RB)	4	5	6	kΩ
Non-linearity <sup>1</sup>	-0.15	0	0.15	% FS
Pressure hysteresis <sup>1</sup>	-0.05	0	0.05	% FS
Operating Temperature <sup>2</sup>	-	-	+185	°C
Max Excitation Voltage	-	5	15	V
TC Sensitivity <sup>3</sup>	-1500	-2200	-2500	PPM/°C
TC Zero Offset <sup>3</sup>	-25	0	25	μV/V/°C
TC Resistance <sup>3</sup>	2300	2800	3300	PPM/°C
Thermal hysteresis <sup>1</sup>	-0.1	0	0.1	% FS

#### Remark:

- All sensors are provided with a control sheet given pressure level versus mVolt @25C° under a supply voltage of 5 Volt.
- Temperature measurement/compensation available. [See our tutorial on our website.](#)
- Conditioning system on request.
- High robustness: specific protection on wire bonding @MEMS level (protection against particles, dust, condensation... ) without impact on frequency measuring range.

1 | Accuracy @25 Celsius ; 2 | TMCL qualification tests – JEDEC JESD22-A104 « temperature cycling » @ Tmax ; 3 | @MEMS level; 4 | Amplification can be done for a special request

## CONTACT

**Operational Headquarter:** Rue des Ormes 151, B-4800 Lambermont, BELGIUM

**TEL:** +32 87 70 96 69

**Email:** sales@sensorade.be