

Annex to the calibration sheet: MHP-3.80-004-SST-S-3000-A-HT

Drawing

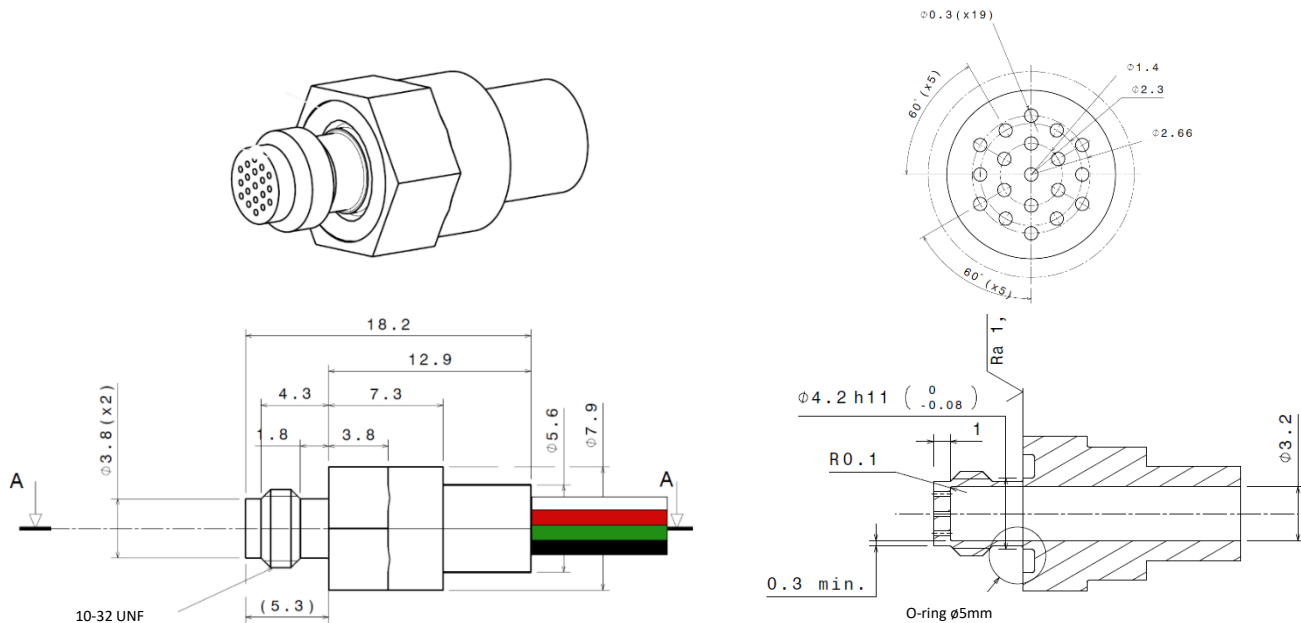

Unit in mm

Additional Technical information

- O-ring:
 - **Inside diameter / tore:** 5mm / 1mm
 - **Material:** Viton (FKM: fluorinated elastomer)
 - **Temperature range:** -20 to 200°C
 - **Reference:** R 2566
- Maximum applicable torque:
 - 1.6 Nm (14 Lb/In)
- Corrosive fluids:
 - Can be used with brake fluid Dot 5.1 for other fluid please contact SENSORADE (sales@Sensorade)
- Assignment wire:
 - **Red wire:** V+
 - **Black wire:** V-
 - **White wire:** S-
 - **Green wire:** S+

Proof Pressure test

- Test at 200 bars at 25°C with oil: Successful (no leak detected, no crack detected on mechanical casing)
- Test at 200 bars at 185°C with oil: Successful(no leak detected, no crack detected on mechanical casing)

CONTACT

Operational Headquarter: Rue des Ormes 151, B-4800 Lambermont, BELGIUM

TEL: +32 87 70 96 69

Email: sales@sensorade.be